

Index
No.

--	--	--	--	--

 -

--

MINISTRY OF EDUCATION, SINGAPORE
PRIMARY SCHOOL LEAVING EXAMINATION**0008/1 (A)****PSLE**
28 September 2018**MATHEMATICS**
PAPER 1
(BOOKLET A)

Additional materials: Optical Answer Sheet (OAS)

Total Time for Booklets A and B : 1 hour**INSTRUCTIONS TO CANDIDATES**

1. Write your Index No. in the boxes at the top right hand corner.
2. Do not turn over this page until you are told to do so.
3. Follow all instructions carefully.
4. Answer all questions.
5. Shade your answers in the Optical Answer Sheet (OAS) provided.
6. The use of calculators is **NOT** allowed.

This booklet consists of 8 printed pages.



Singapore Examinations and Assessment Board

Questions **1** to **10** carry 1 mark each. Questions **11** to **15** carry 2 marks each.
 For each question, four options are given. One of them is the correct answer.
 Make your choice (1, 2, 3 or 4) and shade your answer on the Optical Answer Sheet.

(20 marks)

1 Which of the following is the same as 8040 m?

- (1) 8 km 4 m
- (2) 8 km 40 m
- (3) 80 km 4 m
- (4) 80 km 40 m

2 A, B, C, D are points on a square grid.
 Which point when joined to P and Q forms a right-angled triangle?

- (1) A
- (2) B
- (3) C
- (4) D

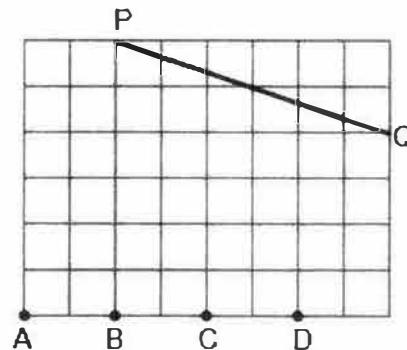

3 What is the length of the paper clip?

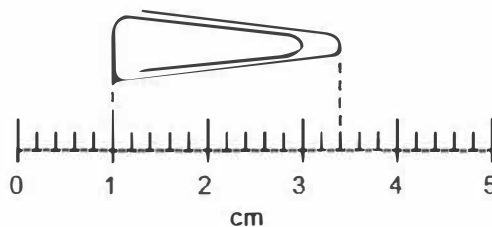

- (1) 2.2 cm
- (2) 2.4 cm
- (3) 3.2 cm
- (4) 3.4 cm

Use the information below to answer Questions 4 and 5.

The graph shows the height of a plant from March to July.

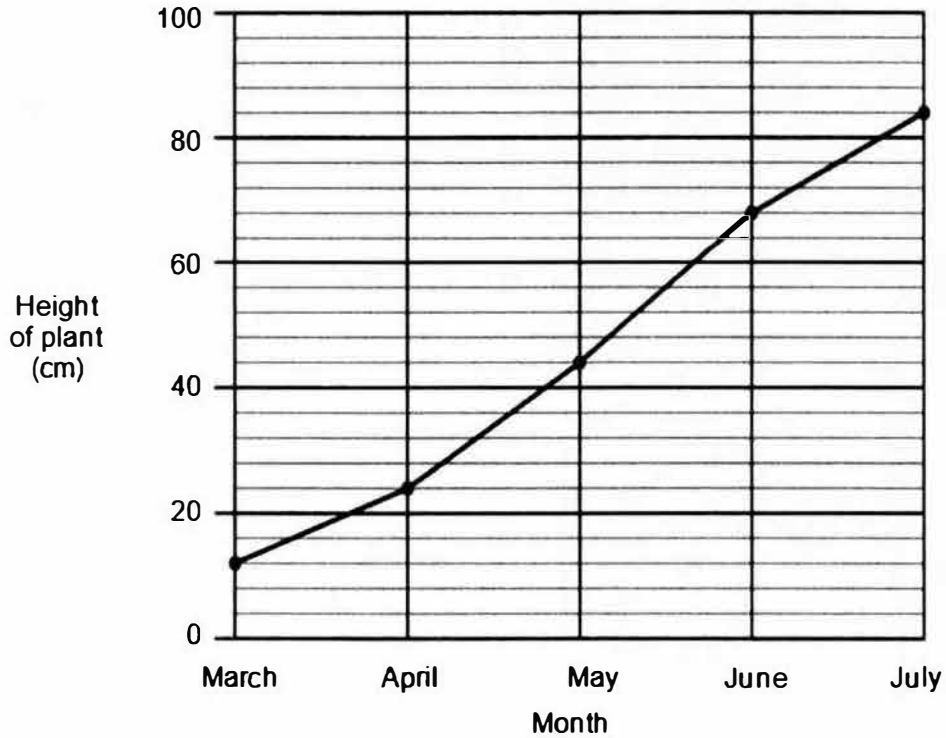

4 What was the height of the plant in June?

- (1) 62 cm
- (2) 64 cm
- (3) 66 cm
- (4) 68 cm

5 In which of the following periods did the plant grow the most?

- (1) March to April
- (2) April to May
- (3) May to June
- (4) June to July

- 6 Four letters Z, E, S, T are shown on a square grid.

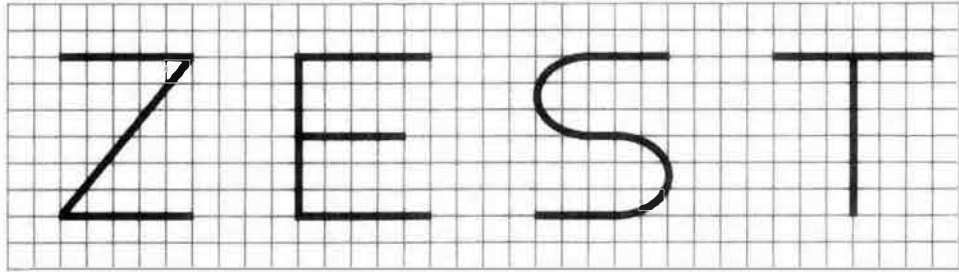

How many of the letters have a line of symmetry?

- (1) 1
 (2) 2
 (3) 3
 (4) 4
- 7 In a class, each pupil chose one animal for their class T-shirt.
 The pie chart shows their choices.

What fraction of the class chose Tiger?

- (1) $\frac{1}{5}$
 (2) $\frac{1}{8}$
 (3) $\frac{2}{5}$
 (4) $\frac{3}{20}$

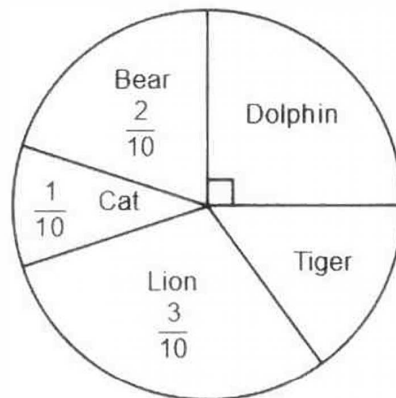

- 8 Arrange the following numbers from the largest to the smallest.

6	6.3	6.03
---	-----	------

Largest

Smallest

- (1) 6 , 6.03 , 6.3
- (2) 6.3 , 6 , 6.03
- (3) 6.3 , 6.03 , 6
- (4) 6.03 , 6.3 , 6
- 9 The figure shows a cuboid with a square base and a height of 2 cm. The area of the shaded face is 18 cm^2 .

What is the volume of the cuboid?

- (1) 36 cm^3
- (2) 72 cm^3
- (3) 108 cm^3
- (4) 162 cm^3

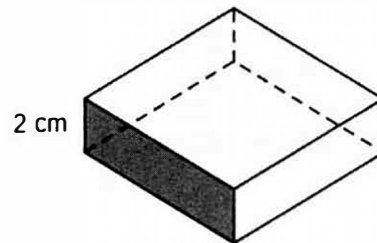

- 10 The table shows the number of pupils with the following scores.

Score	11	12	14	15	17	18	20
Number of pupils	2	3	4	9	5	3	1

A higher score means a better performance. Prizes were given to the top 9 pupils. Arjun won a prize. What was the lowest he could have scored?

- (1) 11
- (2) 14
- (3) 15
- (4) 17

(Go on to the next page)

11 The original price of a file was \$ y . Kumar bought 10 files. He was given a discount of \$1 for every 2 files. How much did he pay altogether?

- (1) $\$(y - 5)$
- (2) $\$(y - 20)$
- (3) $\$(10y - 5)$
- (4) $\$(10y - 20)$

12 The figure shows a pyramid.

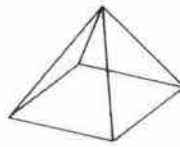

Which of the following is a net of the pyramid?

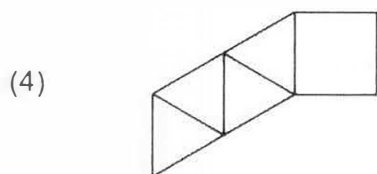
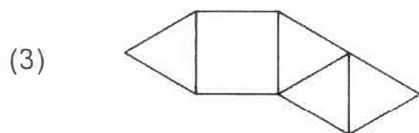
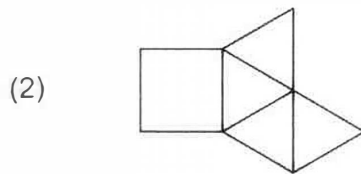
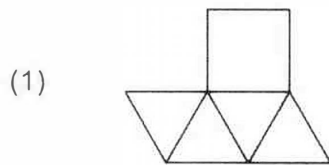

- 13** The figure is formed by joining two quarter circles of radius 4 cm.
 Find the perimeter of the figure. Round your answer to the nearest whole number.
 Take $\pi = 3.14$

- (1) 26 cm
 (2) 27 cm
 (3) 28 cm
 (4) 29 cm

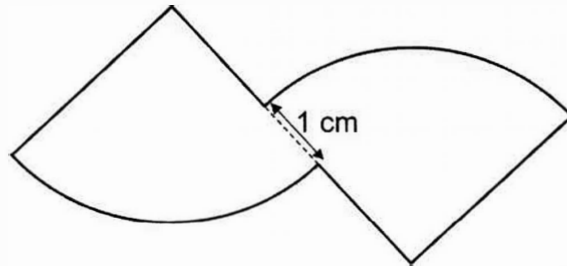

- 14** Rectangle ACEF is made up of two rectangles and two squares.
 $BC = 2$ cm and $CD = 3$ cm.

What fraction of rectangle ACEF is shaded?

- (1) $\frac{1}{3}$
 (2) $\frac{2}{3}$
 (3) $\frac{3}{10}$
 (4) $\frac{11}{40}$

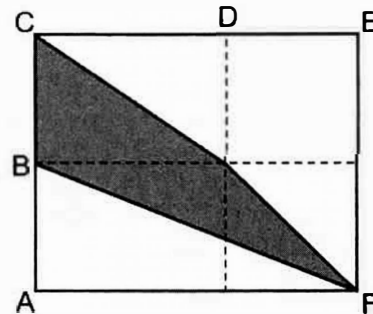

- 15** Two robots Jupiter and Neptune competed in a race.
 The speed of Jupiter was 20 cm/s faster than that of Neptune. When Jupiter crossed the finishing line in 12 seconds, Neptune had only completed $\frac{2}{3}$ of the race.

What was the distance of the race?

- (1) 160 cm
 (2) 240 cm
 (3) 480 cm
 (4) 720 cm

The information contained in this booklet is the property of the Government of the Republic of Singapore. Action will be taken against any person who makes unauthorised release or reproduction of this information, whether in whole or in part and in whatever format.

Those seeking permission to release or reproduce this information, in whole or in part and in whatever format, must direct their request in writing to the **Chief Executive, Singapore Examinations and Assessment Board**.

Any person who comes across this booklet must return it to the **Chief Executive, Singapore Examinations and Assessment Board** without delay.

Copyright Acknowledgements:

The Singapore Examinations and Assessment Board has made every effort to trace copyright holders, but if we have inadvertently overlooked any, we will be pleased to make the necessary arrangements at the first opportunity.

Questions **16** to **20** carry 1 mark each. Write your answers in the spaces provided.
For questions which require units, give your answers in the units stated. (5 marks)

Do not write
in this space

16 Write down one decimal between 2.1 and 2.2

Ans: _____

17 In the figure, AFC and BFE are straight lines. Find $\angle EFD$.

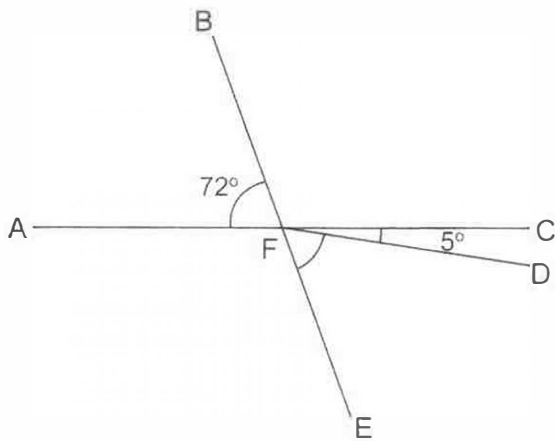

Ans: _____^o

18 Find the value of $3m - 1 + m$ when $m = 7$.

Ans: _____

- 19 Water leaks from a tap at a rate of 5 ml per second.
At this rate, how much water will leak from the tap in 1 minute?

Do not write
in this space

Ans: _____ ml

- 20 Measure and write down the size of $\angle b$.

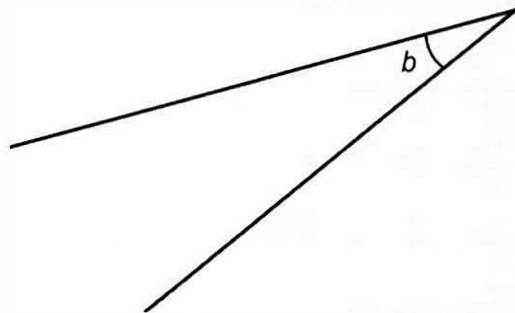

Ans: _____ °

Questions 21 to 30 carry 2 marks each. Show your working clearly and write your answers in the spaces provided. For questions which require units, give your answers in the units stated. (20 marks)

Do not write in this space

21 Three volumes are given below. Which is the smallest? Which is the largest?

1.2ℓ	$1\frac{1}{4} \ell$	$1 \ell 22 \text{ ml}$
------------	---------------------	------------------------

Ans: Smallest: _____

Largest: _____

22 Find the value of 7.26×8 . Give your answer correct to 1 decimal place.

Ans: _____

23 The square grid shows the positions of points A, B, C, D, E, F, G and H.

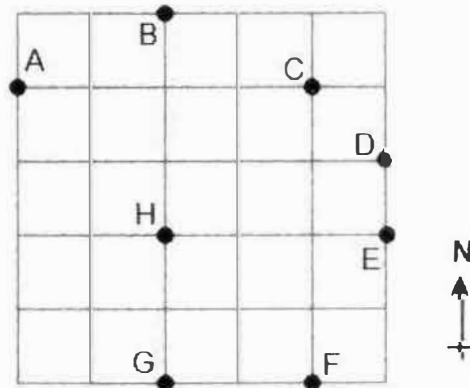

- (a) Cheryl walked directly from point D to point G in a straight line. In which direction did Cheryl walk?
- (b) Devi stood at one of the points facing H. After she turned 45° clockwise, she faced C. Which point was Devi at?

Ans:(a) _____

(b) Point: _____

- 24** Aishah has a roll of wire 10.2 m long.
She cuts off 3 equal pieces. Each piece is 8 cm.
What is the length of the remaining roll of wire? Give your answer in metres.

Do not write
in this space

Ans: _____ m

- 25** Two whole numbers add up to 1037. What is the smallest difference between the two numbers? Write down these two numbers.

Ans: Smallest difference: _____

Numbers: _____ , _____

- 26** Sally had 40 stamps and Ting had 32 stamps.
After Sally gave some of her stamps to Ting, the number of stamps Sally and Ting had were in the ratio 1 : 2.

How many stamps did Ting have in the end?

Ans: _____

- 27 Norah used $\frac{1}{5}$ kg of flour to make muffins and $\frac{1}{2}$ kg of flour to make cookies. After that, she had 360 g of flour left.

How many kilograms of flour did she have at first?

Do not write
in this space

Ans: _____ kg

- 28 Jasmin formed two cuboids with unit cubes. The length, breadth and height of the bigger cuboid are 2 times those of the smaller cuboid. She used 384 unit cubes to form the bigger cuboid.

How many unit cubes did she use to form the smaller cuboid?

Ans: _____

- 29 At first, Liz had an equal number of red and blue stickers. She gave away $\frac{2}{3}$ of her red stickers and some blue stickers. In the end, she was left with $\frac{1}{4}$ of her stickers. What fraction of her blue stickers did Liz give away?

Do not write
in this space

Ans: _____

- 30 The figure shows two circles. The diameter of the big circle is 3 times the diameter of the small circle. The diameter of the big circle is 42 cm.
Find the area of the shaded part. Take $\pi = \frac{22}{7}$

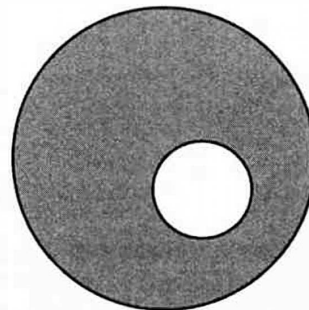

Ans: _____ cm²

End of Paper

The information contained in this booklet is the property of the Government of the Republic of Singapore. Action will be taken against any person who makes unauthorised release or reproduction of this information, whether in whole or in part and in whatever format.

Those seeking permission to release or reproduce this information, in whole or in part and in whatever format, must direct their request in writing to the **Chief Executive, Singapore Examinations and Assessment Board**.

Any person who comes across this booklet must return it to the **Chief Executive, Singapore Examinations and Assessment Board** without delay.

Copyright Acknowledgements:

The Singapore Examinations and Assessment Board has made every effort to trace copyright holders, but if we have inadvertently overlooked any, we will be pleased to make the necessary arrangements at the first opportunity.

Index No.

--	--	--	--	--	--	--	--	--	--

 -

--

MINISTRY OF EDUCATION, SINGAPORE
PRIMARY SCHOOL LEAVING EXAMINATION

0008/2

PSLE

28 September 2018

MATHEMATICS
PAPER 2

Time : 1 h 30 min

- INSTRUCTIONS TO CANDIDATES**
1. Write your Index No. in the boxes at the top right hand corner.
 2. Do not turn over this page until you are told to do so.
 3. Follow all instructions carefully.
 4. Answer all questions.
 5. Write your answers in this booklet.
 6. The use of an approved calculator is allowed.

FOR MARKERS' USE

Question No.	Marker ID	
	Marker 1	Marker 2
1		
2		
3		
4		
5		
6		
7		
8		
9		
10		
11		
12		
13		
14		
15		
16		
17		

FOR CSM / SM / ASM's USE

Supervisor ID / Signature

FOR RECORDER'S USE

Total Mark	Max Mark	Recorder ID / Signature
	55	

Questions 1 to 5 carry 2 marks each. Show your working clearly and write your answers in the spaces provided. For questions which require units, give your answers in the units stated. (10 marks)

Do not write in this space

- 1 Terry made 90 cupcakes. For every 15 cupcakes, Terry used 3 eggs. How many eggs did he use altogether?

Ans: _____

- 2 Eric took 2 hours to travel $\frac{3}{5}$ of a journey. He completed the remaining 84 km in 1 hour. What was Eric's average speed for the whole journey?

Ans: _____ km/h

- 3 For a recycling project, Ali collected 17 bottles, Bala collected $2m$ bottles and Carl collected $2 + m$ bottles.

Each of the statements below is either true, false or not possible to tell from the information given. For each statement, put a tick (\checkmark) to indicate your answer.

Statement	True	False	Not possible to tell
Ali collected the most number of bottles.			
Bala collected more bottles than Carl.			
The 3 boys collected $3m + 19$ bottles altogether.			

- 4 Two rectangular mats, each 6 m by 4 m, are placed on the floor of a rectangular room as shown. The mats overlap. The area of the floor covered by the overlap is 5.2 m^2 .

Find the area of the floor **not** covered by the mats.

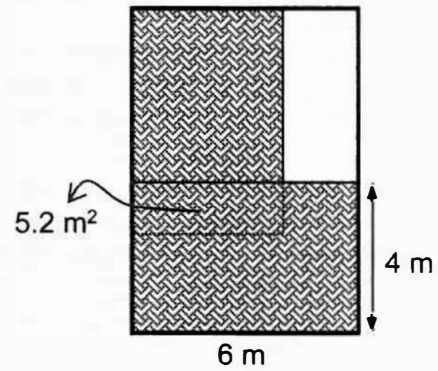

Do not write in this space

Ans: _____ m^2

- 5 Ken had \$15 more than Lisa at first. After Ken gave some of his money to Lisa, he had \$21 less than Lisa.

How much money did Ken give to Lisa?

Ans: \$ _____

For questions 6 to 17, show your working clearly and write your answers in the spaces provided. The number of marks available is shown in brackets [] at the end of each question or part-question. (45 marks)

Do not write in this space

6 Vera bought three types of fruit. The prices are given below.

Type of fruit	Price per fruit
Apple	40¢
Pear	80¢
Mango	\$1.10

The bar graph shows the number of each type of fruit Vera bought.

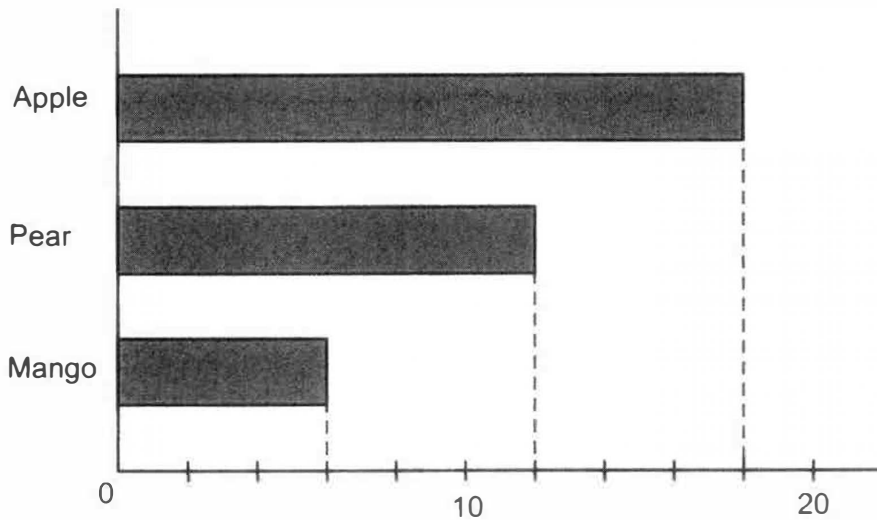

- (a) What fraction of the fruits Vera bought were apples? Give your answer in the simplest form.
- (b) On which type of fruit did Vera spend the most? How much did she spend on that type of fruit?

Ans: (a) _____ [1]

(b) Fruit: _____, _____ [2]

- 7 The pattern on the tile ABCD shows three overlapping squares of different sizes. $AF = FE$ and $AE = ED$.

Do not write in this space

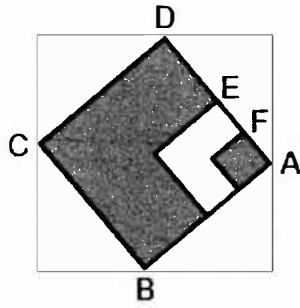

- (a) What fraction of the tile ABCD is shaded?
- (b) Figure Y is made up of four such tiles. The area of the **unshaded** part of Figure Y is 81 cm^2 .

Figure Y

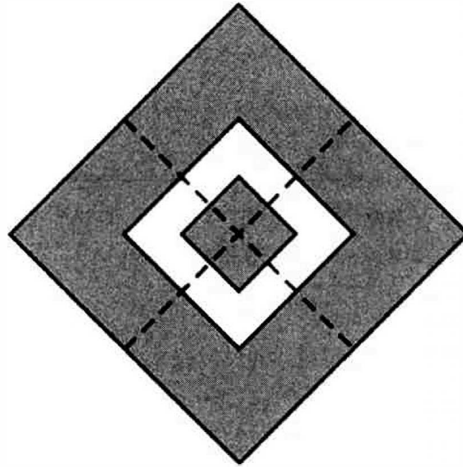

What is the total area of the shaded parts in Figure Y?

Ans: (a) _____ [1]

(b) _____ [2]

- 8 In the figure below, ABE is an equilateral triangle and BCDE is a rhombus.
 $\angle EAC = 38^\circ$.

Find $\angle DEB$.

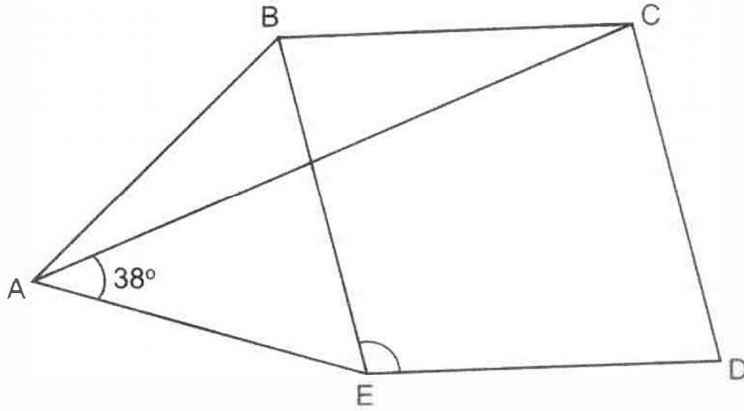

Do not write
in this space

Ans: _____ [3]

- 9 Mr Tan packed 508 tarts into large and small boxes to sell. He filled each large box with 20 tarts and each small box with 12 tarts. All the boxes were full and there was no tart left over.

Do not write
in this space



Large box



Small box

What was the least number of boxes used by Mr Tan?

Ans: _____ [3]

10 John stacked 8 unit cubes and glued them together to form the solid below.

Do not write
in this space

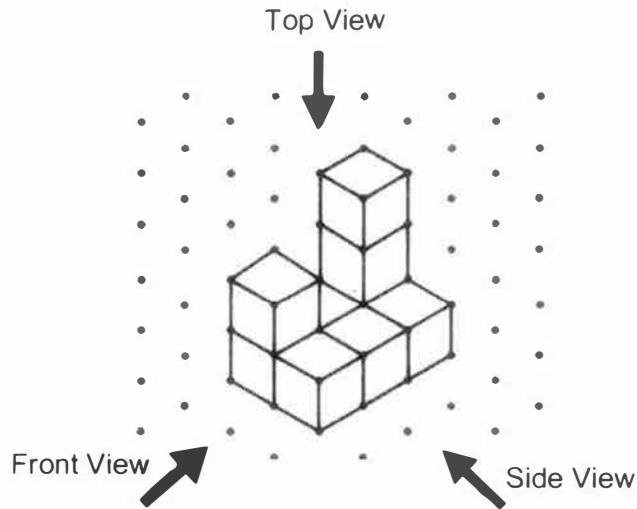

(a) Draw the front view and the side view of the solid on the grids below.

Front View

Side View



[2]

(b) John painted the whole solid, including the base, red.
How many of the 8 cubes had exactly four of their faces painted red?

Ans: (b) _____ [1]

11 The graph shows the fare a taxi company charges for the first 10 kilometres.

Do not write
in this space

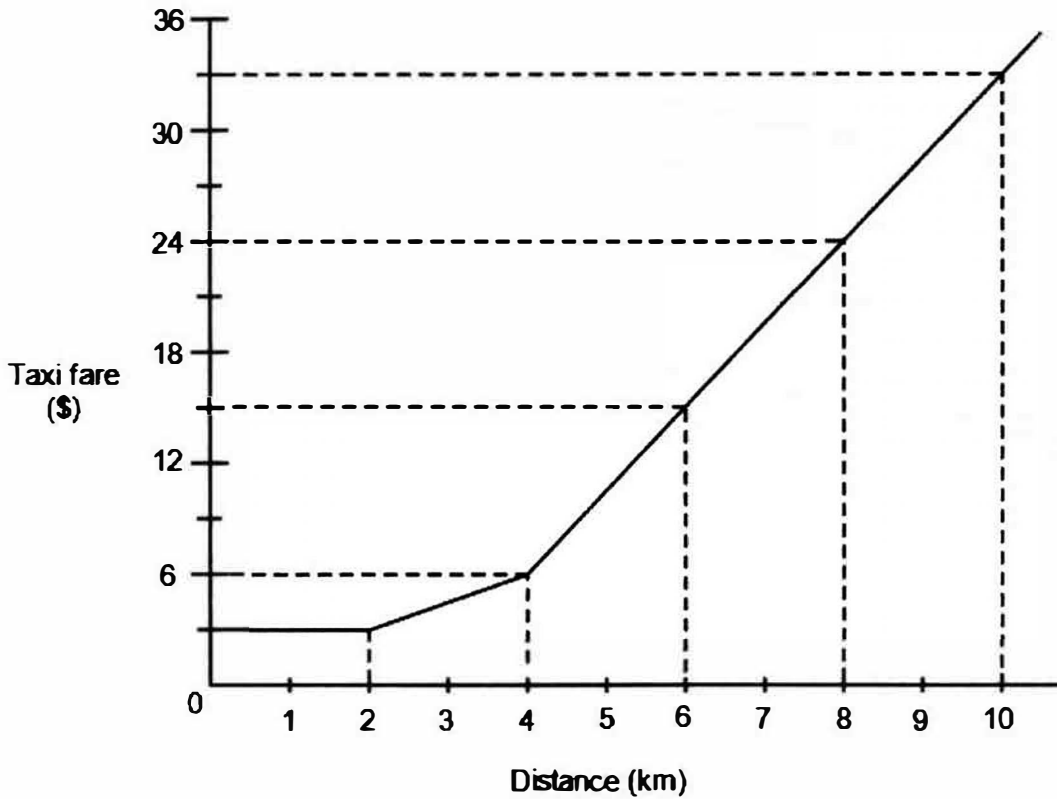

- (a) How much is the taxi fare for the first kilometre?
- (b) Weiming paid \$6 for his taxi ride. What was the distance he travelled?
- (c) How much does the taxi company charge for every kilometre after 4 km of travel?

Ans: (a) _____ [1]

(b) _____ [1]

(c) _____ [2]

- 12 In the figure below, ACDE is a trapezium. CD is parallel to AE. BCD is a straight line and $AB = BC$.

Do not write in this space

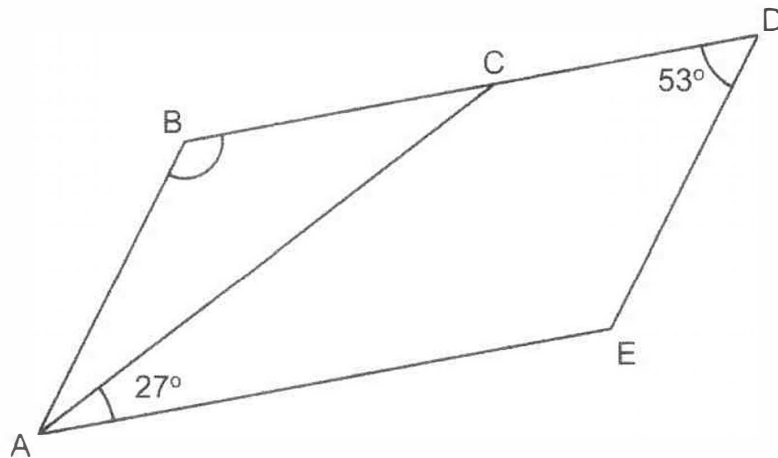

- (a) Find $\angle ABC$.

Ans: (a) _____ [3]

- (b) Circle the words that describe ABDE correctly in the following statement:

ABDE (is / is not) a parallelogram because AB (is / is not) parallel to ED.

[1]

- 13 The bar graph shows the number of visitors to a museum from Monday to Friday last week.

Do not write
in this space

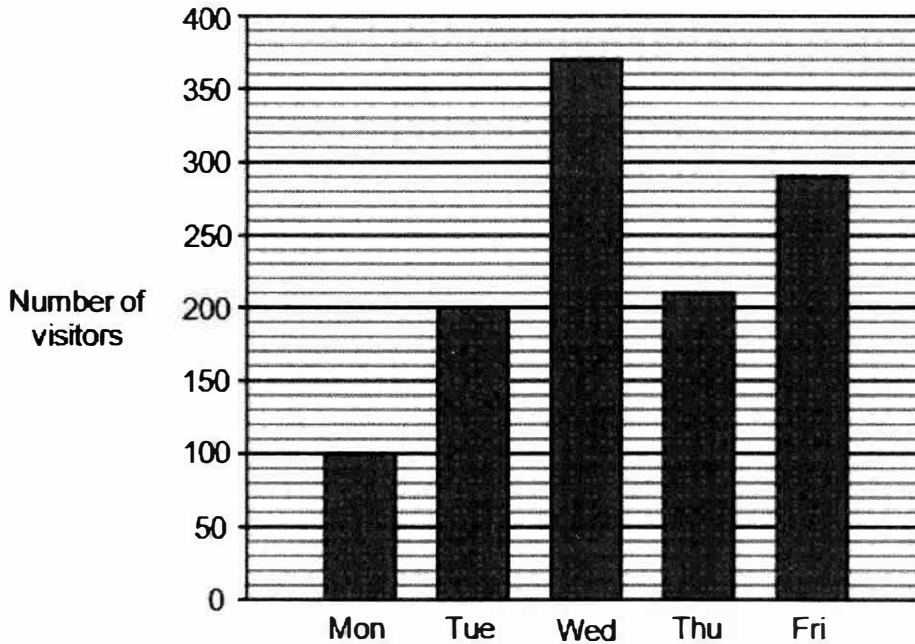

- (a) What was the average number of visitors from Monday to Friday last week?
- (b) The average number of visitors on Saturday and Sunday was 16 more than the average number of visitors from Monday to Friday.

Write down one possible set of values for the number of visitors on Saturday and Sunday.

Ans: (a) _____ [2]

(b) _____ , _____ [2]

- 14 Ann had a total of 285 red and blue beads. She used 45 red beads and 40% of the blue beads. After that, the ratio of the number of red beads to blue beads Ann had was 1 : 3.
- (a) What fraction of her blue beads did Ann use?
Give your answer in the simplest form.
- (b) How many beads did Ann have in the end?

Do not write
in this space

Ans: (a) _____ [1]

(b) _____ [3]

- 15 X and Y are two rectangular containers. The base area of X is 30 cm^2 and the base of Y has dimensions as shown. X contained 780 cm^3 of water and Y was empty.

Do not write
in this space

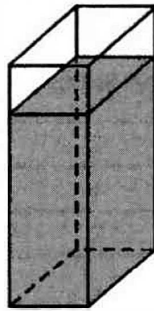

X

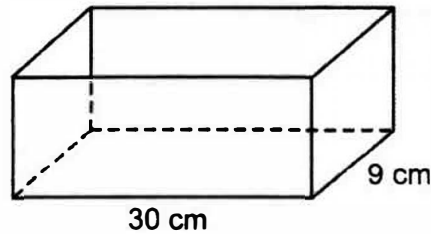

Y

- (a) What was the height of the water level in X?
- (b) Sam poured some water from X into Y without spilling. After that, the height of the water level of X was the same as that of Y. How much water did Sam pour into Y?

Ans: (a) _____ [1]

(b) _____ [3]



16 Lily saved \$60 in February. This amount was a 20% increase from what she saved in January. The amount she saved in March was a 15% decrease from what she saved in February.

- (a) What was the total amount that Lily saved from January to March?
- (b) What was the percentage increase in the amount Lily saved in March compared to January?

Do not write
in this space

Ans: (a) _____ [3]

(b) _____ [2]

- 17 In a shop, candles are sold only in boxes. A box of 7 short candles costs \$2.50 and a box of 5 long candles costs \$3.20.

Do not write
in this space

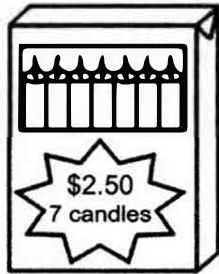

Box of Short Candles

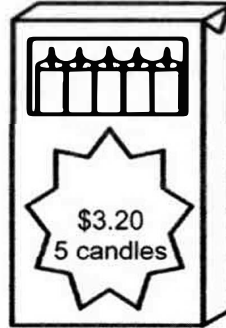

Box of Long Candles

- (a) Dan wants 19 short candles and 3 long candles for his lanterns. What is the least amount of money that Dan will need to spend on the candles?
- (b) Eva bought 21 more long candles than short candles from the shop. The total number of candles she bought was fewer than 50. How much did Eva spend on the candles altogether?

Ans: (a) _____ [2]

(b) _____ [3]

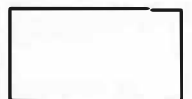

End of Paper

The information contained in this booklet is the property of the Government of the Republic of Singapore. Action will be taken against any person who makes unauthorised release or reproduction of this information, whether in whole or in part and in whatever format.

Those seeking permission to release or reproduce this information, in whole or in part and in whatever format, must direct their request in writing to the **Chief Executive, Singapore Examinations and Assessment Board**.

Any person who comes across this booklet must return it to the **Chief Executive, Singapore Examinations and Assessment Board** without delay.

Copyright Acknowledgements:

The Singapore Examinations and Assessment Board has made every effort to trace copyright holders, but if we have inadvertently overlooked any, we will be pleased to make the necessary arrangements at the first opportunity.