

Index
No.

						-	
--	--	--	--	--	--	---	--

MINISTRY OF EDUCATION, SINGAPORE
PRIMARY SCHOOL LEAVING EXAMINATION

0008/1 (A)

PSLE
2022MATHEMATICS
PAPER 1
(BOOKLET A)

Additional materials: Optical Answer Sheet (OAS)

Total Time for Booklets A and B : 1 hour

INSTRUCTIONS TO CANDIDATES

1. Write your index number in the boxes at the top right-hand corner.
2. Do not turn over this page until you are told to do so.
3. Follow all instructions carefully.
4. Answer all questions.
5. Use a 2B pencil to shade your answers on the Optical Answer Sheet (OAS).
6. The use of calculators is **NOT** allowed.

This booklet consists of 7 printed pages and 1 blank page.



Singapore Examinations and Assessment Board

Questions 1 to 10 carry 1 mark each. Questions 11 to 15 carry 2 marks each.
 For each question, four options are given. One of them is the correct answer.
 Make your choice (1, 2, 3 or 4) and shade your answer on the Optical Answer Sheet.

(20 marks)

1 What is the value of the digit 2 in 20 345?

- (1) 20
- (2) 200
- (3) 2000
- (4) 20 000

2 Express $1\frac{1}{20}$ as a decimal.

- (1) 1.1
- (2) 1.5
- (3) 1.05
- (4) 1.12

3 The position of a bench in a garden with corners P, Q, R and S is shown. The bench is south-east of one of the corners. Which corner is it?

- (1) P
- (2) Q
- (3) R
- (4) S

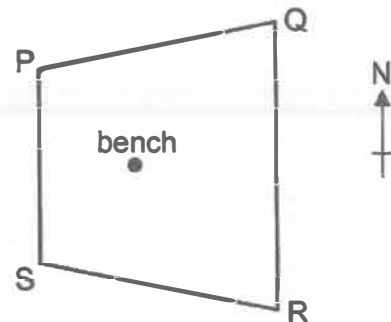

4 Which of the following shows $\frac{1}{4}$ of the figure shaded?

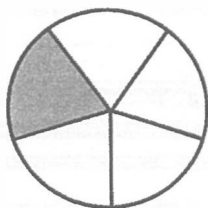

(1)

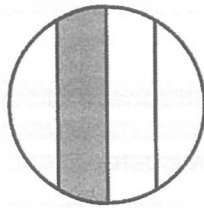

(2)

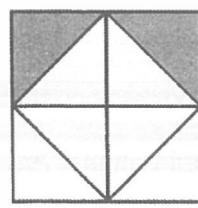

(3)

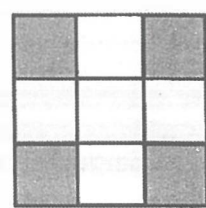

(4)

5 Five letters are drawn on the square grid.

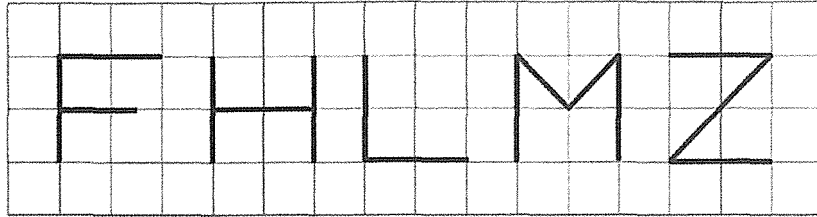

How many of the letters have both parallel and perpendicular lines?

- (1) 5
- (2) 2
- (3) 3
- (4) 4

6 The number of children at a camp increased by 50 from Monday to Tuesday and decreased by 20 from Tuesday to Wednesday. Which graph shows the number of children at the camp from Monday to Wednesday?

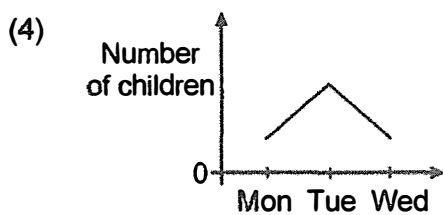
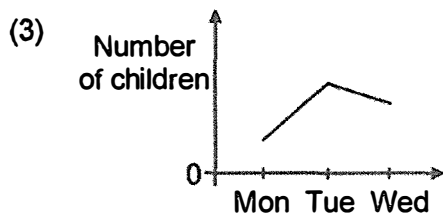
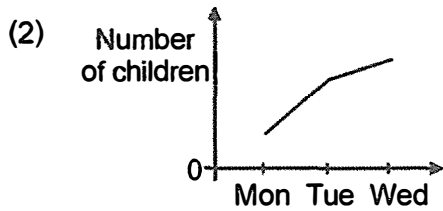
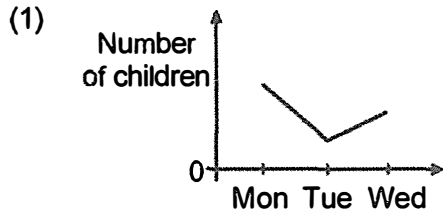

7 Arrange from the largest to the smallest: 0.4, 0.44, 0.404

	<u>Largest</u>		<u>Smallest</u>		
(1)	0.4	,	0.404	,	0.44
(2)	0.44	,	0.404	,	0.4
(3)	0.44	,	0.4	,	0.404
(4)	0.404	,	0.44	,	0.4

8 Which of the following is not a net of a cube?

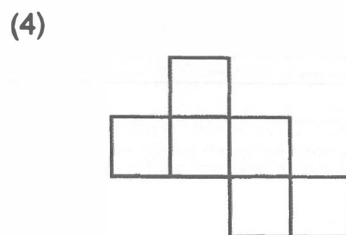
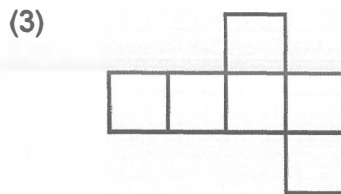
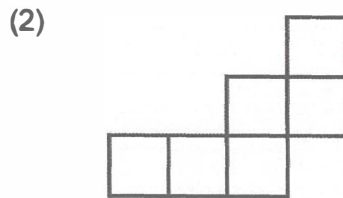
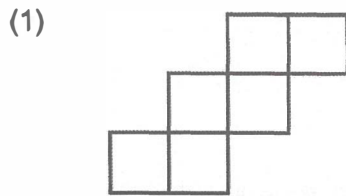

- 9 The pie chart shows the number of pens, erasers, rulers and notebooks sold by a shop. The same information is shown in a bar graph, but the names of the items are not shown on the bar graph.

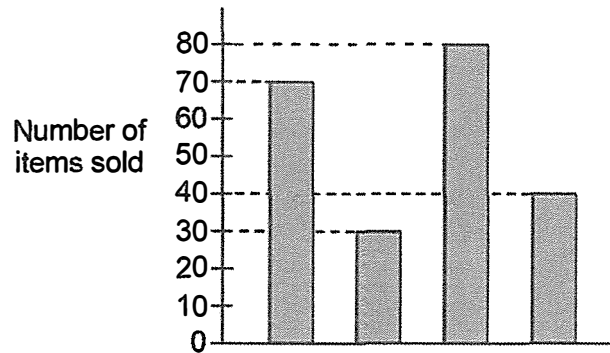
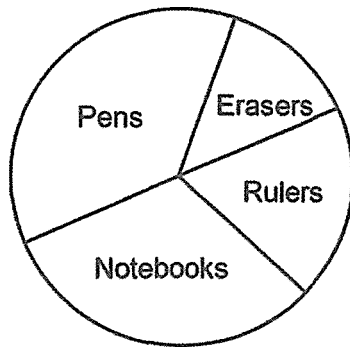

How many more pens than erasers are sold?

- (1) 10
 (2) 30
 (3) 40
 (4) 50
- 10 The bus schedule for the airport is shown.

<u>Leaves bus interchange</u>	<u>Reaches airport</u>
7.30 a.m.	8.15 a.m.
7.45 a.m.	8.30 a.m.
8.20 a.m.	9.05 a.m.
8.45 a.m.	9.30 a.m.
9.30 a.m.	10.15 a.m.

Devi misses the 7.30 a.m. bus by 45 minutes. What is the earliest time she can reach the airport by bus?

- (1) 8.15 a.m.
 (2) 8.30 a.m.
 (3) 9.05 a.m.
 (4) 9.30 a.m.

11 In the number line, what is the value represented by A?

- (1) 5.30
- (2) 5.60
- (3) 5.75
- (4) 6.25

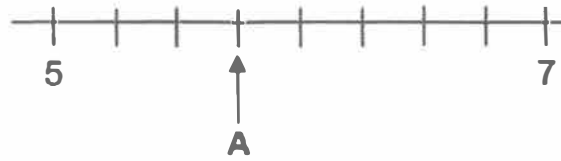

12

Container	Number of pens	Percentage of pens which are green
A	100	4%
B	300	8%

What percentage of the total number of pens in containers A and B are green?

- (1) 6%
- (2) 7%
- (3) 3%
- (4) 12%

13 A rectangular piece of paper is folded to form a trapezium PQRS. The two shaded triangles are identical. Find $\angle x$.

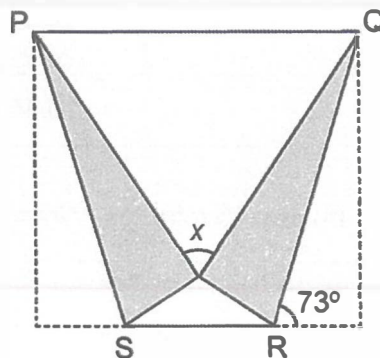

- (1) 34°
- (2) 56°
- (3) 60°
- (4) 68°

- 14 Dots are placed at an equal distance from each other along the 6 sides of shape A. The number of dots on each side is the same and each corner has a dot on it.

When there are 18 dots on shape A, there are 4 dots on each side.

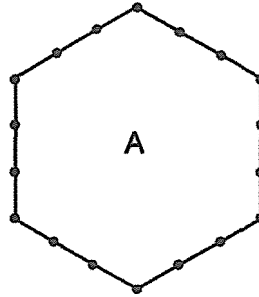

18 dots

When there are 96 dots on shape A, how many dots are there on each side?

- (1) 15
 (2) 16
 (3) 17
 (4) 18
- 15 Matthew pushes two sticks, A and B, straight into the ground until the length of each stick that is above the ground is the same.

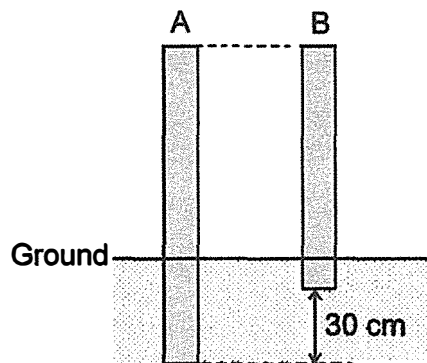

$\frac{1}{3}$ of A and $\frac{1}{8}$ of B are in the ground. The length of A in the ground is 30 cm longer than the length of B in the ground. What is the total length of sticks A and B?

- (1) 318 cm
 (2) 258 cm
 (3) 222 cm
 (4) 162 cm

BLANK PAGE

Copyright Acknowledgements:

The Singapore Examinations and Assessment Board has made every effort to trace copyright holders, but if we have inadvertently overlooked any, we will be pleased to make the necessary arrangements at the first opportunity.

MINISTRY OF EDUCATION, SINGAPORE
PRIMARY SCHOOL LEAVING EXAMINATION

0008/1 (B)

PSLE
2022

MATHEMATICS
PAPER 1
(BOOKLET B)

Total Time for Booklets A and B : 1 hour

INSTRUCTIONS TO CANDIDATES

1. Please check that your name, school and index number are printed **CORRECTLY** on the barcode label.
2. Do not turn over this page until you are told to do so.
3. Follow all instructions carefully.
4. Answer all questions.
5. Use a dark blue or black ballpoint pen to write your answers in the space provided for each question.
6. Do not use correction fluid/tape or highlighters.
7. The use of calculators is **NOT** allowed.

This booklet consists of 7 printed pages and 1 blank page.

Questions 16 to 20 carry 1 mark each. Write your answers in the spaces provided.
For questions which require units, give your answers in the units stated.

(5 marks)

16 Write eleven thousand and twenty in numerals.

Ans: _____

17 Find the value of $6402 \div 6$

Ans: _____

18 Round 32.553 to the nearest tenth.

Ans: _____

19 Find the value of 0.35×80

Ans: _____

20 Callie had 1.02 kg of flour at first. She used 450 g of it.
How many kilograms of flour was left?

Ans: _____ kg

Questions 21 to 30 carry 2 marks each. Show your working clearly and write your answers in the spaces provided. For questions which require units, give your answers in the units stated.
(20 marks)

21 (a) Find the value of $1 - \frac{1}{4} - \frac{1}{6}$

Ans: (a) _____

(b) Write down one fraction between $\frac{1}{5}$ and $\frac{2}{5}$

Ans: (b) _____

22 The square grid shows line AB.

(a) AB is one side of a triangle ABC with $\angle ACB = 90^\circ$. Draw triangle ABC.

(b) AB is also the side of a square ABDE. Draw square ABDE.

Use a pencil to draw your diagrams and label them clearly.

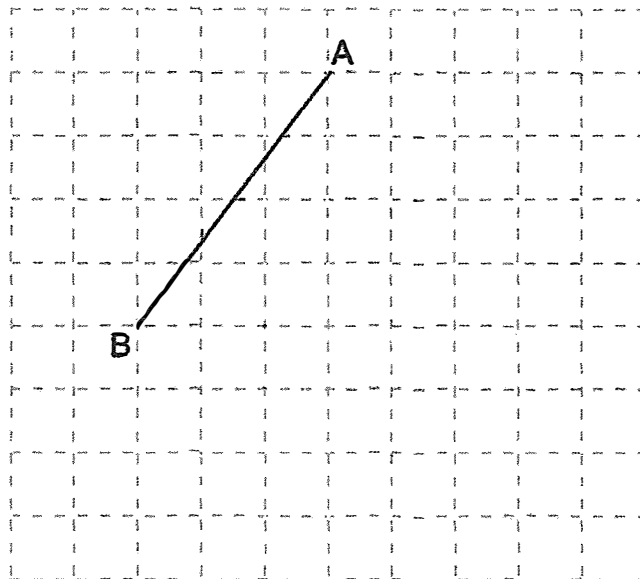

(Go on to the next page)

- 23 The table shows the number of children at a swimming club from January to March.

Month	Number of Children
January	16
February	24
March	30

- (a) Find the ratio of the number of children in January to February to March. Give your answer in the simplest form.

Ans: (a) _____

- (b) The ratio of the number of children in March to April was the same as the ratio of the number of children in January to February. How many children were there in April?

Ans: (b) _____

- 24 The airmail rates to a country are shown.

Letters	First 20 g	22y ¢
	Every additional 10 g or less	6y ¢
Postcards (per piece)		70 ¢

Rashid sent 2 postcards and a letter. The letter weighed 33 g. How much did Rashid pay in total? Give your answer in terms of y in the simplest form.

Ans: _____ ¢

- 25 The sum of two numbers is 79. One of the numbers is a multiple of 7. The other number is a factor of 27. What is the difference between the two numbers?

Ans: _____

- 26 Ben cycles at a constant speed from home to school. The graph shows the distance Ben cycles for the first 15 minutes.

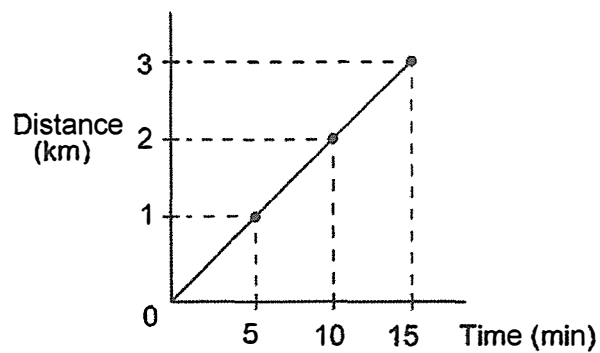

The distance between Ben's home and school is 7.5 km.

- (a) How many minutes does Ben take to cycle from home to school?

Ans: (a) _____ min

- (b) What is Ben's cycling speed in km/h?

Ans: (b) _____ km/h

(Go on to the next page)

- 27 Mohan glued 15 cubes of side 1 cm to form the solid shown.

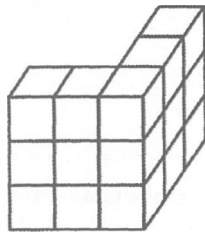

- (a) Mohan painted the whole solid, including the base. What was the total painted area?

Ans: (a) _____ cm^2

- (b) Mohan added some cubes of side 1 cm to the solid to form a cuboid 3 cm by 5 cm by 5 cm. How many cubes did he add?

Ans: (b) _____

-
- 28 A square and a triangle have equal perimeters. The lengths of the three sides of the triangle are 6.1 cm, 8.2 cm and 9.7 cm. What is the area of the square?

Ans: _____ cm^2

- 29 A pattern is formed using the letters A, B and C. The first 15 letters are shown.

A B A C A A B A C A A B A C A.....
1st 15th

The letter A appears 137 times in the pattern. What is the greatest possible number of letters in the pattern?

Ans: _____

- 30 At first, a bag contained 9 red beads and some blue beads. After some red beads were added to the bag, $\frac{2}{5}$ of the beads were blue. Then, 56 yellow beads were added to the bag and now, $\frac{2}{9}$ of the beads were blue. How many red beads were added to the bag?

Ans: _____

End of Paper

BLANK PAGE

Copyright Acknowledgements:

The Singapore Examinations and Assessment Board has made every effort to trace copyright holders, but if we have inadvertently overlooked any, we will be pleased to make the necessary arrangements at the first opportunity.

MINISTRY OF EDUCATION, SINGAPORE
PRIMARY SCHOOL LEAVING EXAMINATION

0008/2

PSLE
2022MATHEMATICS
PAPER 2

Time : 1 hour 30 minutes**INSTRUCTIONS TO CANDIDATES**

1. Please check that your name, school and index number are printed **CORRECTLY** on the barcode label.
2. Do not turn over this page until you are told to do so.
3. Follow all instructions carefully.
4. Answer all questions.
5. Use a dark blue or black ballpoint pen to write your answers in the space provided for each question.
6. Do not use correction fluid/tape or highlighters.
7. The use of an approved calculator is allowed.

This booklet consists of 15 printed pages and 1 blank page.

Questions 1 to 5 carry 2 marks each. Show your working clearly and write your answers in the spaces provided. For questions which require units, give your answers in the units stated. (10 marks)

1

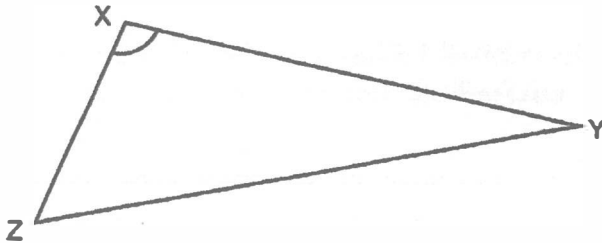

Measure and write down

(a) the length of XY.

Ans: (a) _____ cm

(b) the size of $\angle YXZ$.

Ans: (b) _____ °

2

Mariam had caps for sale. In the morning, she sold $\frac{1}{3}$ of the caps. In the afternoon, she sold $\frac{1}{5}$ of the remaining caps. After that, there were 56 caps left. How many caps did Mariam have at first?

Ans: _____

3

A zoo gives a 20% discount on all tickets on weekdays. Members are then given a further discount of \$2 for every ticket they buy. Liming is a member and pays \$54 for 5 tickets on a weekday. What is the price of each ticket without any discount?

Ans: \$ _____

- 4 The pie charts show the number of each type of fish in two fish tanks, A and B. The total number of fish in Tank A is twice the total number of fish in Tank B.

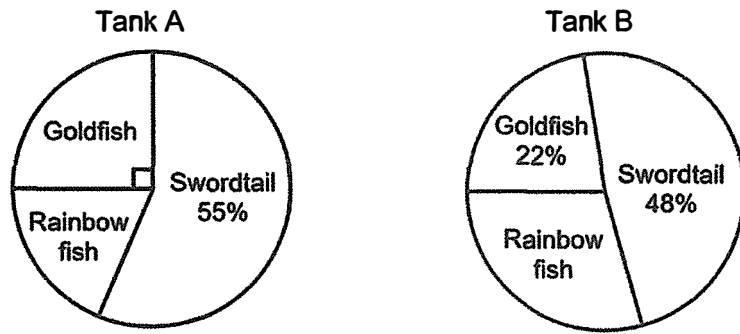

Each statement is either true, false or not possible to tell from the information given. Put a tick (✓) to indicate your answer.

Statement	True	False	Not possible to tell
There are 55 swordtails in Tank A.			
$\frac{1}{3}$ of the fish in Tank B are rainbow fish.			
There are more rainbow fish in Tank A than in Tank B.			

- 5 The number of boys and girls in a hall were in the ratio 2 : 5. After 11 boys entered the hall and half the number of girls left the hall, the ratio of the number of boys to girls became 1 : 1. How many children were there in the hall at first?

Ans: _____

(Go on to the next page)

For questions 6 to 17, show your working clearly and write your answers in the spaces provided. The number of marks available is shown in brackets [] at the end of each question or part-question. (45 marks)

- 6 The graph shows the amount of money David saved from his pocket money every month from January to May.

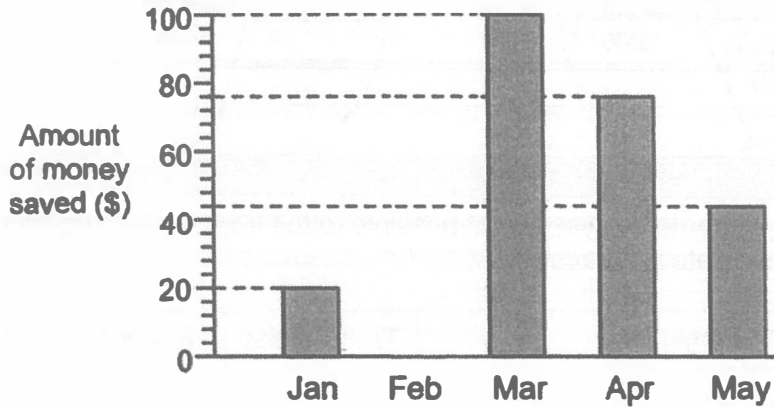

- (a) How much money did David save altogether from January to May?

Ans: (a) _____ [1]

- (b) What was the average amount of money David saved from January to May?

Ans: (b) _____ [1]

- (c) David saved \$75 in June. The amount saved increased by 100% from June to July and another 100% from July to August. How much money did David save in August?

Ans: (c) _____ [1]

7 The graph shows the temperature of water in a pot from 09 00 to 09 30.

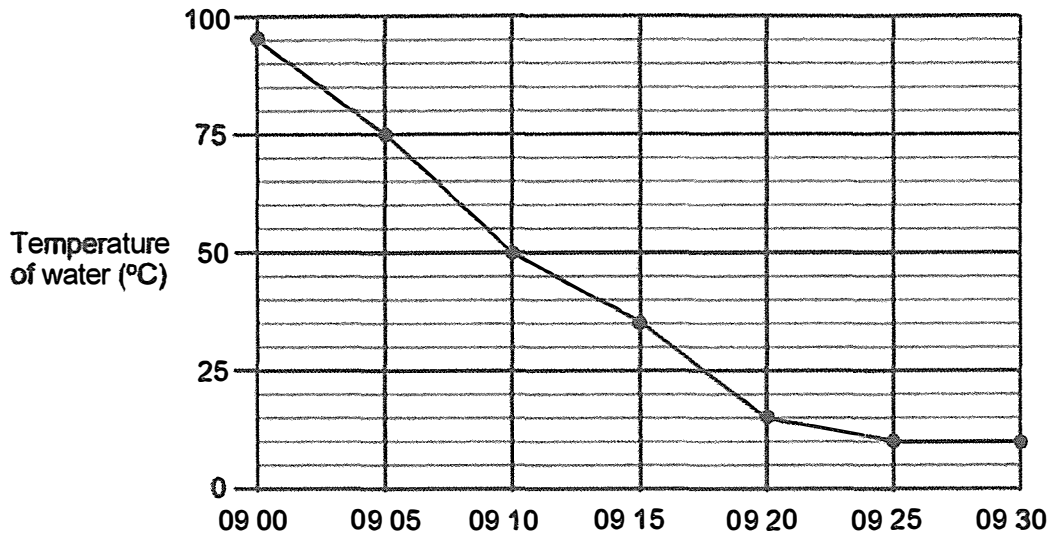

(a) For how many minutes was the temperature of the water 50°C and below?

Ans: (a) _____ [1]

(b) During which two 5-minute intervals did the temperature of water decrease at the same rate?

Ans: (b) _____ to _____
_____ to _____ [1]

(c) What was the change in temperature per minute from 09 25 to 09 30?
Give your answer in °C per minute.

Ans: (c) _____ [1]

(Go on to the next page)

- 8 John designed a logo as shown. The logo is made up of 3 small identical quarter circles, a large quarter circle and 2 straight lines drawn inside a square of side 42 cm. The radius of each small quarter circle is 14 cm.

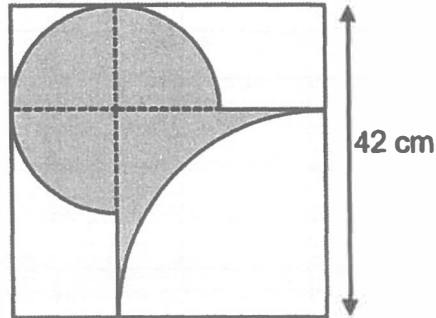

(Take $\pi = \frac{22}{7}$)

- (a) What is the perimeter of the shaded part?

Ans: (a) _____ [2]

- (b) What is the area of the shaded part?

Ans: (b) _____ [2]

9 ABCD and DBEF are rhombuses. DGC is a straight line.

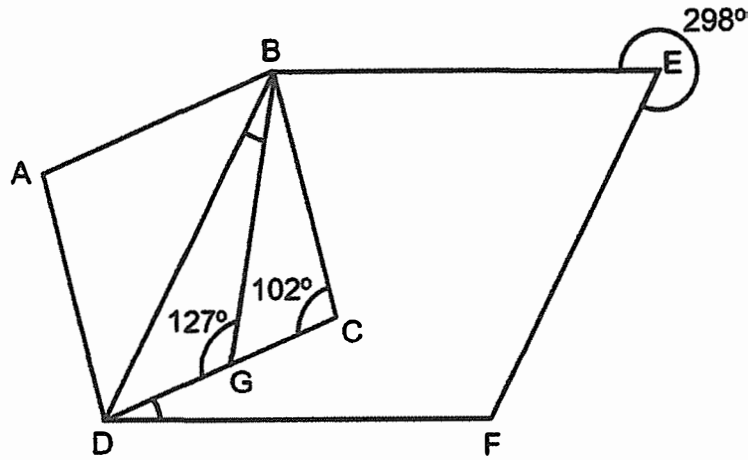

(a) Find $\angle DBG$.

Ans: (a) _____ [2]

(b) Find $\angle FDC$.

Ans: (b) _____ [1]

(Go on to the next page)

10 When Jane started jogging from her home, Linda was 1.2 km ahead. Jane jogged at 10 km/h and Linda walked at 4 km/h. They went in the same direction and did not change their speeds throughout.

(a) How far did Jane jog in 45 minutes?

Ans: (a) _____ [1]

(b) Who was ahead after 45 minutes? How far apart were they?

Ans: (b) _____ was ahead

Distance apart: _____ [2]

- 11 The figure is made up of two rectangles, ABHF and FGDE, and two right-angled isosceles triangles, BCH and DCG. BA = 12 cm, DE = 8 cm and BH = x cm. AFE and CHGF are straight lines.

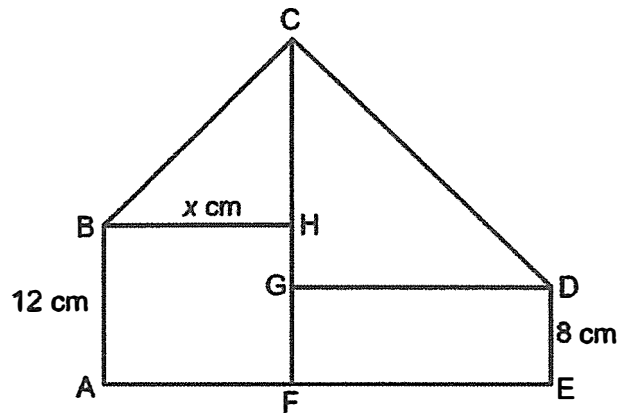

- (a) Find the length of AE in terms of x . Give your answer in the simplest form.

Ans: (a) _____ [1]

- (b) Find the total area of the figure when $x = 14$.

Ans: (b) _____ [2]

(Go on to the next page)

12 ABCD is a parallelogram, ACE is an equilateral triangle and $DC = DE$.

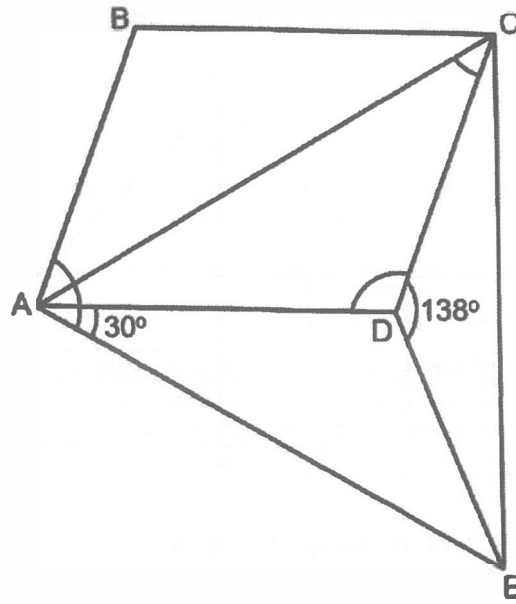

(a) Find $\angle ACD$.

Ans: (a) _____ [2]

(b) Find $\angle CDA$.

Ans: (b) _____ [1]

(c) Find $\angle EAB$.

Ans: (c) _____ [1]

- 13 Lily has identical building blocks. Each block has a square base and a height, h cm as shown in Figure 1.

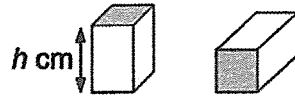

Figure 1

She uses these blocks to build two towers, A and B, as shown in Figure 2. The height of A is 58 cm, and the height of B is 94 cm as shown in Figure 3.

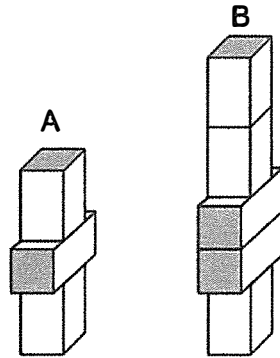

Figure 2

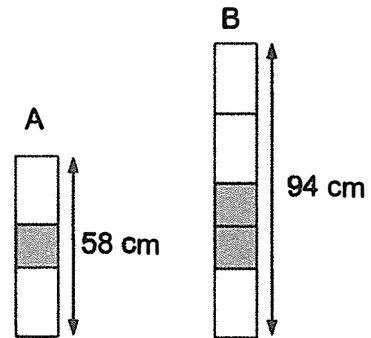

Figure 3

- (a) What is the height, h of each block?

Ans: (a) _____ [2]

- (b) What is the volume of each block?

Ans: (b) _____ [2]

(Go on to the next page)

- 14 The figure shows the amount of water in two rectangular containers, X and Y, at first.

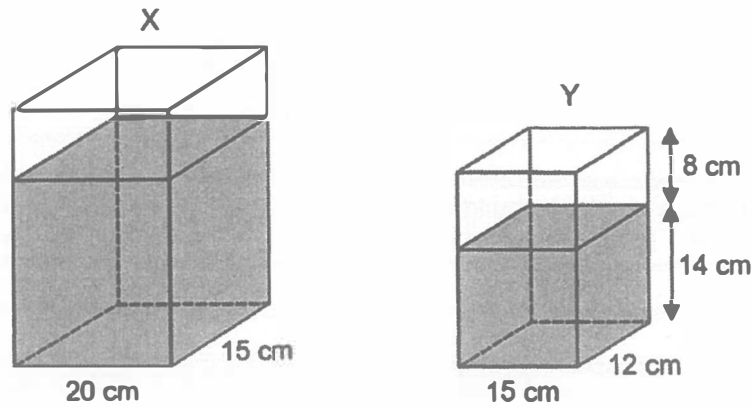

Ray poured $\frac{1}{5}$ of the water from X into Y to fill it to the top, without overflowing.

- (a) How much water was there in X at first?

Ans: (a) _____ [2]

- (b) Ray then poured all the water from Y into X. 120 cm^3 of water overflowed from X. What was the height of X?

Ans: (b) _____ [3]

15 Muthu spent $\frac{4}{7}$ of his money to buy 6 identical pens. He spent the rest of his money to buy another 4 such pens and 3 identical files.

- (a) What fraction of Muthu's money was spent to buy the 3 files?
Give your answer in the simplest form.

Ans: (a) _____ [2]

- (b) For every 5 files bought, 1 additional file was given free. How many files would Muthu get in total if he were to spend all his money to buy files only?

Ans: (b) _____ [2]

(Go on to the next page)

- 16 A plot of land of area 876 m^2 is divided into three rectangular fields of equal width. The fields are fenced using 177 m of fencing, indicated by in the figure below.

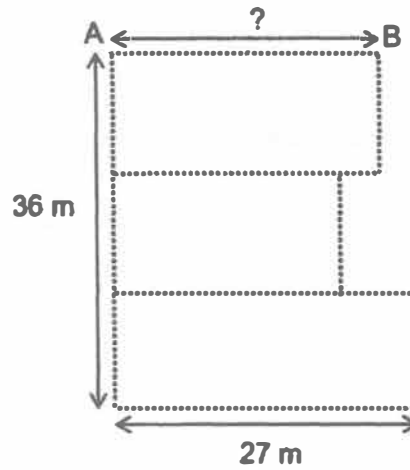

- (a) Find the length of AB.

Ans: (a) _____ [2]

- (b) Find the perimeter of the plot of land.

Ans: (b) _____ [3]

- 17** Mrs Li baked a total of 40 large and small cakes in the ratio 5 : 3. She decorated them with cherries. The number of cherries used for each large and small cake was in the ratio 3 : 2. She used 204 cherries to decorate all the small cakes and 7 large cakes.

(a) How many small cakes did Mrs Li bake?

Ans: (a) _____ [1]

(b) How many cherries did Mrs Li use for all the small cakes?

Ans: (b) _____ [2]

(c) How many more cherries did Mrs Li need for the remaining large cakes?

Ans: (c) _____ [1]

End of Paper

BLANK PAGE

Copyright Acknowledgements:

The Singapore Examinations and Assessment Board has made every effort to trace copyright holders, but if we have inadvertently overlooked any, we will be pleased to make the necessary arrangements at the first opportunity.