

--	--	--	--	--	--	--	--	--	--

MINISTRY OF EDUCATION, SINGAPORE
PRIMARY SCHOOL LEAVING EXAMINATION

0008/1 (A)

PSLE
2 OCTOBER 2015

MATHEMATICS
PAPER 1
(BOOKLET A)

Additional materials: Optical Answer Sheet (OAS)

Total Time for Booklets A and B : 50 min

INSTRUCTIONS TO CANDIDATES

1. Write your Index No. in the boxes at the top right hand corner.
2. Do not turn over this page until you are told to do so.
3. Follow all instructions carefully.
4. Answer all questions.
5. Shade your answers in the Optical Answer Sheet (OAS) provided.
6. The use of calculators is **NOT** allowed.

This booklet consists of 8 printed pages.



Singapore Examinations and Assessment Board

Questions 1 to 10 carry 1 mark each. Questions 11 to 15 carry 2 marks each.
 For each question, four options are given. One of them is the correct answer.
 Make your choice (1, 2, 3 or 4) and shade your answer on the Optical Answer Sheet.
 (20 marks)

1 Round off 31 804 to the nearest thousand.

- (1) 30 000
- (2) 31 000
- (3) 31 800
- (4) 32 000

2 Six angles are marked in the figure. How many of them are larger than a right angle?

- (1) 5
- (2) 2
- (3) 3
- (4) 4

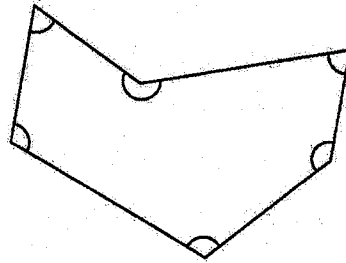

3 In the figure, PQ and RS are straight lines. Which one of the following is true?

- (1) $\angle a = \angle c$
- (2) $\angle b = \angle d$
- (3) $\angle a + \angle c = 180^\circ$
- (4) $\angle b + \angle d = 180^\circ$

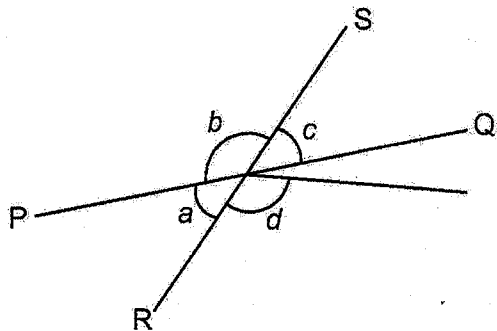

4 Find the value of $9g - 4 + 2g$ when $g = 6$.

- (1) 18
- (2) 38
- (3) 46
- (4) 62

5 A solid cuboid of height 10 cm has a square base of side 3 cm.
What is its volume?

- (1) 30 cm^3
- (2) 90 cm^3
- (3) 180 cm^3
- (4) 300 cm^3

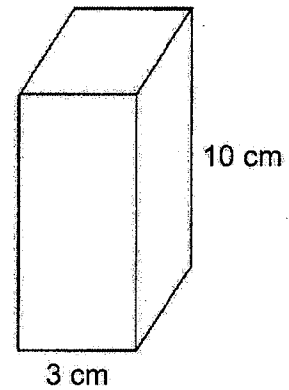

6 Which of the following is likely to be the total mass of 8 one-dollar coins?

- (1) 6 g
- (2) 60 g
- (3) 600 g
- (4) 6000 g



7

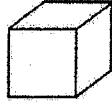

Which of the following is a net of a cube?

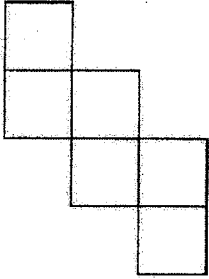

(1)

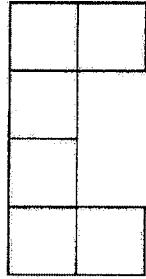

(2)

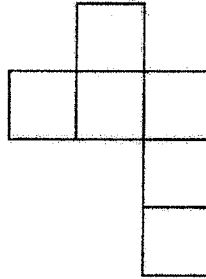

(3)

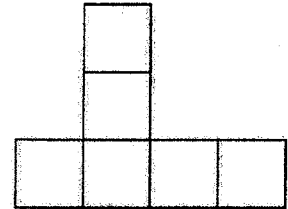

(4)

8 Tai was in school from 7.00 a.m. to 4.00 p.m. yesterday. How many hours was he in school?

- (1) 7
- (2) 9
- (3) 10
- (4) 11

9 The figure below shows the position of a flag pole in a field ABCD. Which corner of the field is south-east of the flag pole?

- (1) A
- (2) B
- (3) C
- (4) D

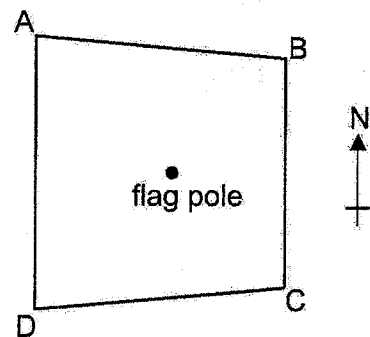

Use the information below to answer questions 10 and 11.

The pie chart below shows the different types of sandwiches at a stall.

$\frac{1}{5}$ of the sandwiches were Tuna and $\frac{1}{4}$ of the sandwiches were either Cheese or Egg.

There were 3 times as many Cheese sandwiches as Egg sandwiches.

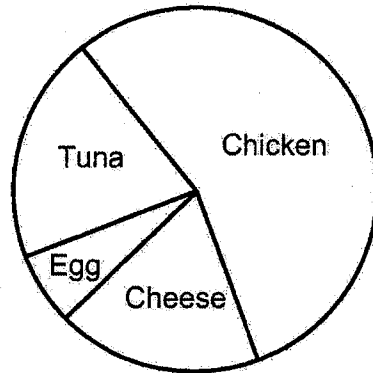

10 What fraction of the sandwiches were Chicken sandwiches?

(1) $\frac{1}{2}$

(2) $\frac{3}{4}$

(3) $\frac{9}{20}$

(4) $\frac{11}{20}$

11 What fraction of the sandwiches were Egg sandwiches?

(1) $\frac{1}{12}$

(2) $\frac{1}{16}$

(3) $\frac{1}{3}$

(4) $\frac{1}{4}$

12 Arrange these distances from the shortest to the longest:

3.15 km, $3\frac{1}{5}$ km, 3 km 105 m

	<u>Shortest</u>		<u>Longest</u>
(1)	3 km 105 m,	3.15 km,	$3\frac{1}{5}$ km
(2)	3 km 105 m,	$3\frac{1}{5}$ km,	3.15 km
(3)	$3\frac{1}{5}$ km,	3.15 km,	3 km 105 m
(4)	3.15 km,	$3\frac{1}{5}$ km,	3 km 105 m

13 Figure 1 is a trapezium with a perimeter of 36 cm. Figure 2 is made up of four such trapeziums. The perimeter of Figure 2 is 96 cm.

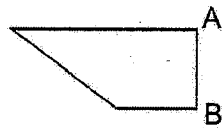

Figure 1

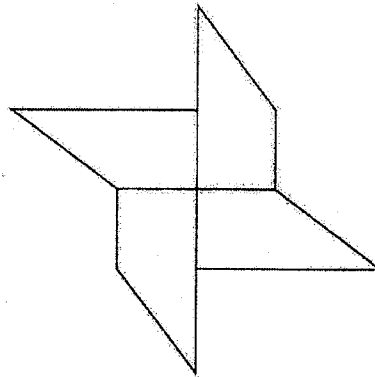

Figure 2

What is the length of the side AB of the trapezium?

- (1) 15 cm
- (2) 12 cm
- (3) 3 cm
- (4) 6 cm

14 A number when divided by 30 gives a remainder of 8. Which of the following can be added to the number to change it to a multiple of 6?

- (1) 6
- (2) 2
- (3) 5
- (4) 4

15 Ling and Juni made greeting cards over two days. On Saturday, Ling made 19 cards more than Juni. On Sunday, Ling made another 20 cards and Juni made another 15. At the end of the two days, Ling made $\frac{3}{5}$ of the total number of cards. What was the number of cards Juni made?

- (1) 24
- (2) 26
- (3) 48
- (4) 78

The information contained in this booklet is the property of the Government of the Republic of Singapore. Action will be taken against any person who makes unauthorised release or reproduction of this information, whether in whole or in part and in whatever format.

Those seeking permission to release or reproduce this information, in whole or in part and in whatever format, must direct their request in writing to the **Chief Executive, Singapore Examinations and Assessment Board**.

Any person who comes across this booklet must return it to the **Chief Executive, Singapore Examinations and Assessment Board** without delay.

Copyright Acknowledgements:

The Singapore Examinations and Assessment Board has made every effort to trace copyright holders, but if we have inadvertently overlooked any, we will be pleased to make the necessary arrangements at the first opportunity.

--	--	--	--	--	--	--	--	--	--	--	--

MINISTRY OF EDUCATION, SINGAPORE
 PRIMARY SCHOOL LEAVING EXAMINATION

0008/1 (B)

PSLE
2 OCTOBER 2015

MATHEMATICS
PAPER 1
(BOOKLET B)

Total Time for Booklets A and B : 50 min

INSTRUCTIONS TO CANDIDATES

1. Write your Index No. in the boxes at the top right hand corner.
2. Do not turn over this page until you are told to do so.
3. Follow all instructions carefully.
4. Answer all questions.
5. Write your answers in this booklet.
6. The use of calculators is **NOT** allowed.

FOR MARKERS' USE

Question No.	Marker ID	
	Marker 1	Marker 2
16 – 19		
20 – 22		
23 – 25		
26 – 27		
28 – 29		
30		

FOR CSM / SM / ASM's USE

Supervisor ID / Signature

FOR RECORDER'S USE

Total Mark	Max Mark	Recorder ID / Signature
	20	

This booklet consists of 8 printed pages.



Singapore Examinations and Assessment Board

Questions 16 to 25 carry 1 mark each. Write your answers in the spaces provided. For questions which require units, give your answers in the units stated. (10 marks)

Do not write in this space

- 16 Find the value of $8020 \div 5$.

Ans: _____

- 17 Find the average of 9 and 14.

Ans: _____

- 18 In the figure, ABC is a straight line. Find $\angle k$.

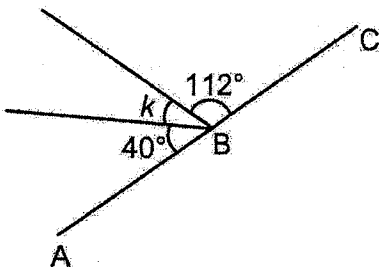

Ans: _____ °

- 19 The figure is made up of 3 squares. One square is divided equally into 4 triangles. What fraction of the figure is shaded?

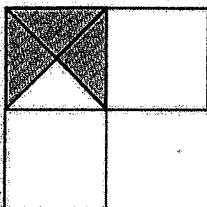

Ans: _____

Use the figure below to answer questions 20 and 21.

The figure shows five roads drawn on a map in a square grid.

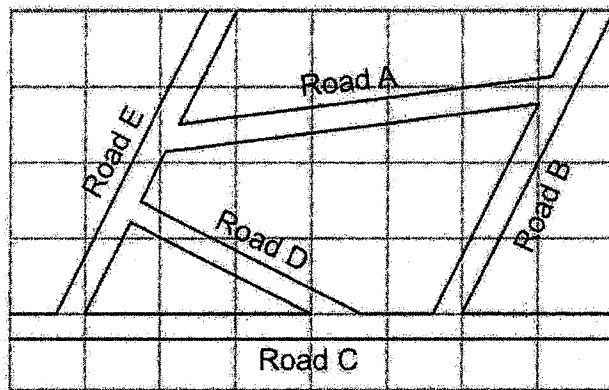

Do not write
in this space

- 20 Name two roads that are parallel to each other.

Ans: _____ and _____

- 21 Name two roads that are perpendicular to each other.

Ans: _____ and _____

- 22 What is the price of the watch after adding 7% GST?

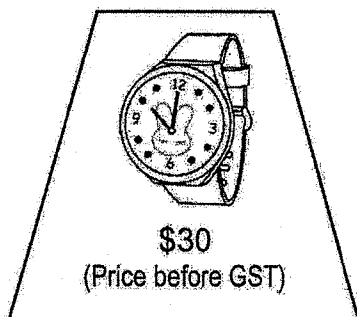

Ans: \$ _____

- 23 How much water (in ml) is in the container?

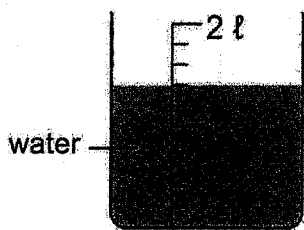

Do not write
in this space

Ans: _____ ml

Use the figure below to answer questions 24 and 25.

A semicircle is drawn inside a box.

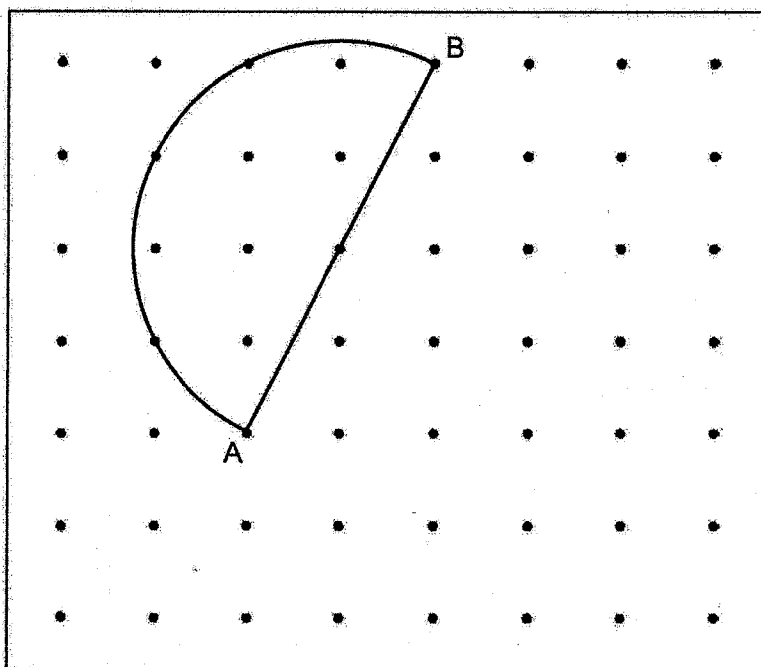

- 24 Measure and write down the length of the radius of the semicircle.

Ans: _____ cm

- 25 C is one of the dots inside the box. Draw two lines AC and BC to complete a triangle ABC with $AB = AC$.

Questions 26 to 30 carry 2 marks each. Show your working clearly and write your answers in the spaces provided. For questions which require units, give your answers in the units stated. (10 marks)

Do not write in this space

- 26 The bar graph shows the number of children in the families living in a block of flats. $\frac{1}{3}$ of the families have 1 child. Draw the bar that shows the number of these families in the graph.

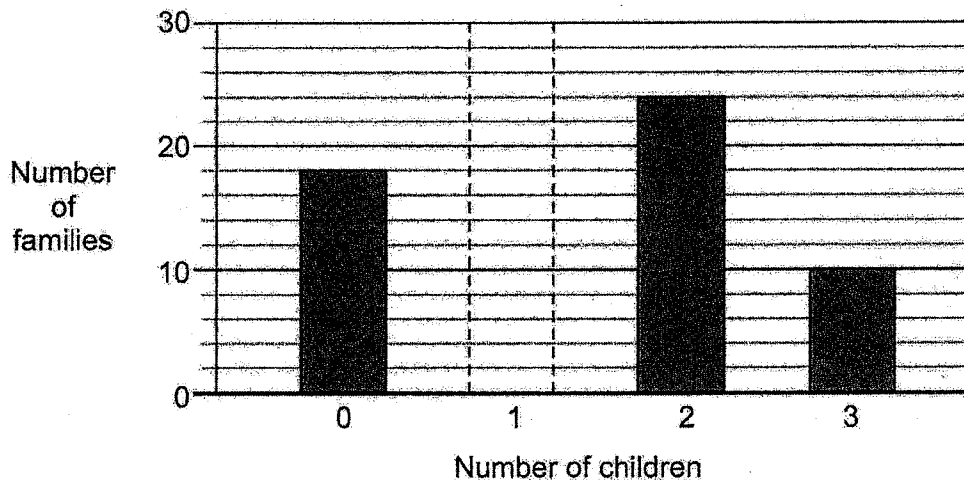

- 27 The table shows how much a company charges for a cleaning job.

First 3 hours	\$80
Every additional hour	\$20

Mrs Menon paid the company \$200 for a cleaning job. How many hours of cleaning did she pay for?

Ans: _____ h

- 28 Sam drew five figures shown below. **A** is a circle, **B** is an equilateral triangle, **C** is a parallelogram, **D** is a rhombus and **E** is a trapezium.

Do not write
in this space

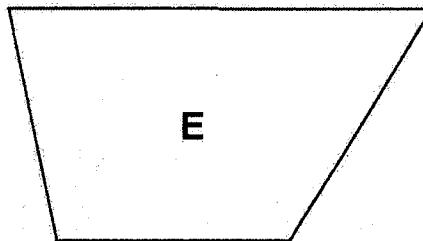
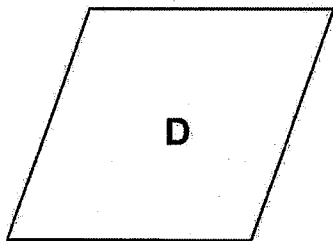
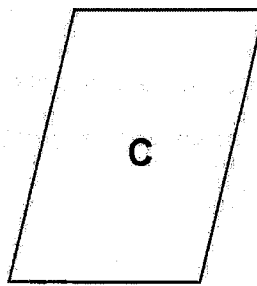
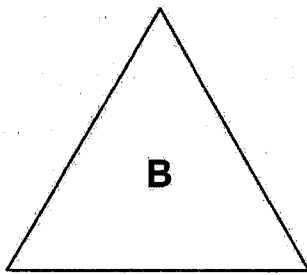
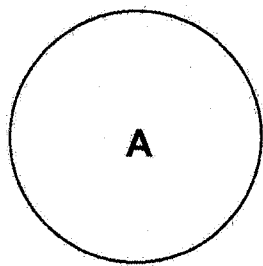

Name all the figures above that have at least one line of symmetry.

Ans: _____

- 29 A bag contains straws of three different colours. $\frac{1}{4}$ of the straws are blue. The ratio of the number of red straws to that of green straws is 2 : 3. What is the ratio of the number of blue straws to that of green straws?

Ans: _____

- 30 Meng wanted to build a set of steps with 1-cm cubes (). The figures below show how he built the steps, from a height of 2 cm to 3 cm to 4 cm.

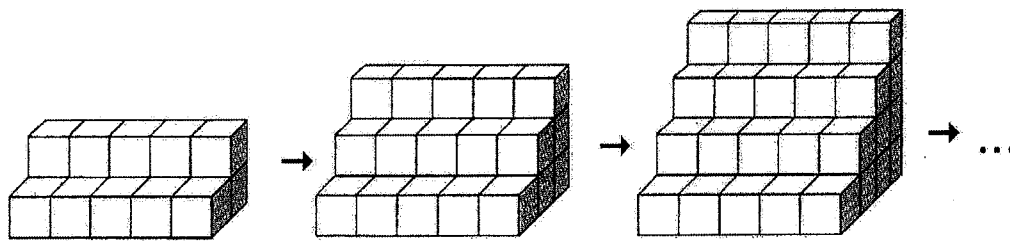

If Meng continued building the steps in this way, what would be the height of the set of steps that had 140 cubes?

Do not write
in this space

Ans: _____ cm



The information contained in this booklet is the property of the Government of the Republic of Singapore. Action will be taken against any person who makes unauthorised release or reproduction of this information, whether in whole or in part and in whatever format.

Those seeking permission to release or reproduce this information, in whole or in part and in whatever format, must direct their request in writing to the **Chief Executive, Singapore Examinations and Assessment Board**.

Any person who comes across this booklet must return it to the **Chief Executive, Singapore Examinations and Assessment Board** without delay.

Copyright Acknowledgements:

The Singapore Examinations and Assessment Board has made every effort to trace copyright holders, but if we have inadvertently overlooked any, we will be pleased to make the necessary arrangements at the first opportunity.

MINISTRY OF EDUCATION, SINGAPORE
 PRIMARY SCHOOL LEAVING EXAMINATION

0008/2
PSLE
2 OCTOBER 2015
MATHEMATICS
PAPER 2
Time: 1 h 40 min
INSTRUCTIONS TO CANDIDATES

1. Write your Index No. in the boxes at the top right hand corner.
2. Do not turn over this page until you are told to do so.
3. Follow all instructions carefully.
4. Answer all questions.
5. Write your answers in this booklet.
6. The use of an approved calculator is expected, where appropriate.

FOR MARKERS' USE

Question No.	Marker ID	
	Marker 1	Marker 2
1		
2		
3		
4		
5		
6		
7		
8		
9		
10		
11		
12		
13		
14		
15		
16		
17		
18		

FOR CSM / SM / ASM's USE

Supervisor ID / Signature

FOR RECORDER'S USE

Total Mark	Max Mark	Recorder ID / Signature
	60	

This booklet consists of 15 printed pages and 1 blank page.



Singapore Examinations and Assessment Board

BLANK PAGE

Questions 1 to 5 carry 2 marks each. Show your working clearly and write your answers in the spaces provided. For questions which require units, give your answers in the units stated. (10 marks)

Do not write in this space

- 1 Zaleha bought 1.2 kg of grapes. How much did she pay?

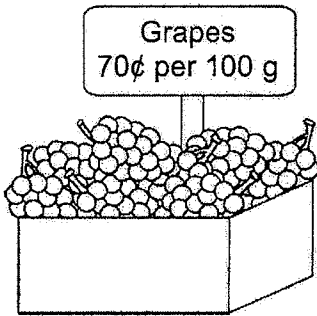

Ans: \$ _____

- 2 Malek paid \$945 for a table and 4 chairs. The price of a chair was $\frac{2}{7}$ of the price of the table. How much did Malek pay for the table?

Ans: \$ _____

- 3 Rei bought 150 oranges and 100 apples for her neighbours. She divided the oranges equally among them and had 17 oranges left. She also divided the apples equally among them and had 5 apples left. How many neighbours were there?

Do not write in this space

Ans: _____

- 4 In the figure, ABCD is a square, EBFG is a rectangle and $\angle EBC = 252^\circ$. Find $\angle ABF$.

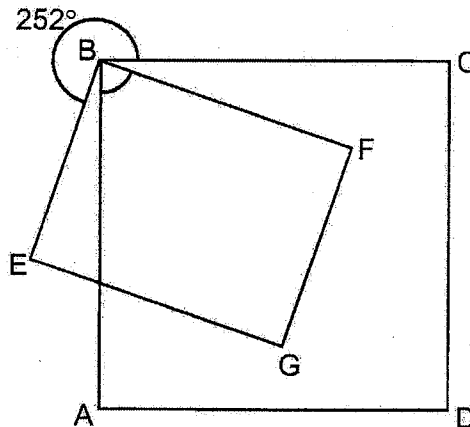

Ans: _____ °

- 5 A player has to play a total of four games in Round 1 of a competition. The scores for Chong's first three games are shown below.

Do not write
in this space

Round 1	
Game	Score
1 st	23
2 nd	21
3 rd	24
4 th	

Chong will qualify for Round 2 if his average score for three of the four games is 25 or more. What is the lowest score Chong must get in the 4th game to qualify for Round 2?

Ans: _____

For questions 6 to 18, show your working clearly and write your answers in the spaces provided. The number of marks available is shown in brackets [] at the end of each question or part-question. (50 marks)

Do not write in this space

- 6 In the figure, CDEF is a parallelogram. AFC and BFE are straight lines and $BA = BC$. $\angle ABF = 30^\circ$ and $\angle DEF = 54^\circ$.

- (a) Find $\angle EFC$.
 (b) Find $\angle FBC$.

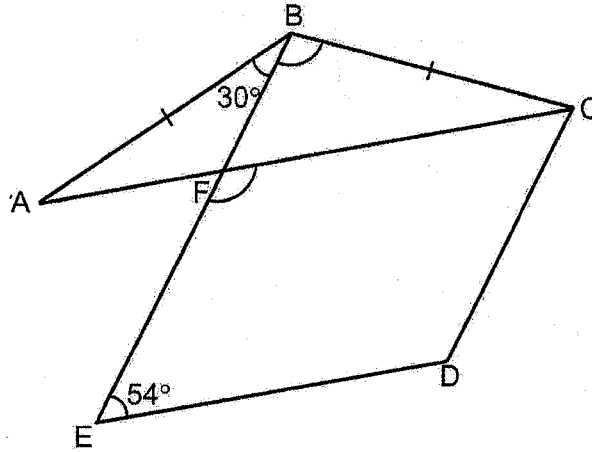

Ans: (a) _____ [1]
 (b) _____ [2]

- 7 At first, Ben had \$90 and Chandra had \$48. Each bought a shirt at the same price. The amounts of money Ben and Chandra had left were in the ratio 4 : 1. How much did the shirt cost?

Ans: _____ [3]

- 8 Liming had a piece of wire $13w$ cm long. He formed a triangle, with sides measuring w cm, $3w$ cm and 20 cm, with part of the wire.
- (a) Express the length of the remaining wire in terms of w in the simplest form.
- (b) Liming used the remaining wire to form a rectangle of length $2w$ cm. If $w = 6$, what was the breadth of the rectangle?

Do not write
in this space

Ans: (a) _____ [1]

(b) _____ [2]

- 9 At a concert, 55% of the tickets were sold at full price and 40% of the tickets at half price. The remaining 20 tickets were given away free. The total amount of money collected was \$7200. What was the full price of a ticket?

Ans: _____ [3]

- 10 A company offered 80 printers at a 25% discount during a 7-day sale. The line graph shows the number of printers left unsold at the end of each day.

Do not write in this space

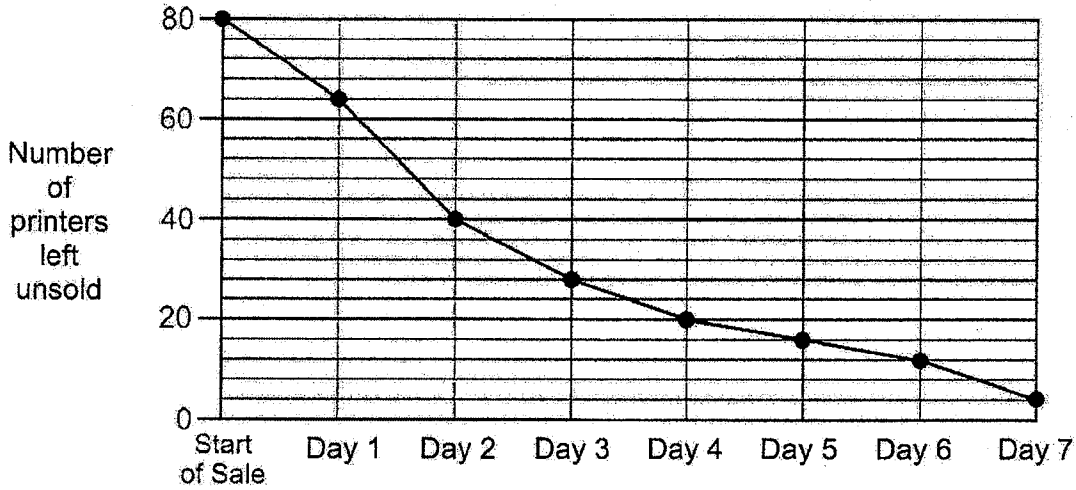

- (a) On which day was the most number of printers sold?
- (b) What percentage of the 80 printers were sold in the first three days of the sale?
- (c) During the sale, the discounted price of the printers was \$120. After the sale, the remaining printers were sold without discount. What was the total amount of money collected from selling all 80 printers?

Ans: (a) _____ [1]

(b) _____ [1]

(c) _____ [3]

- 11 In a school, 70% of the members in the Band and 60% of the members in the Choir are girls. Both the Band and the Choir have the same number of boys. The Band has 20 more girls than the Choir. How many members are there in the Band?

Do not write
in this space

Ans: _____ [3]

- 12 At 11 50, Kiran started cycling at 25 km/h from her home to a park, 10 km away. She was at the park for 1 h 50 min.

- (a) What time did she leave the park?
- (b) After leaving the park, Kiran cycled back along the same route and took 40 min to reach home. What was her average speed, in km/h, for the journey home?

Ans: (a) _____ [2]

(b) _____ [2]

- 13 The figure shows a right-angled triangle.

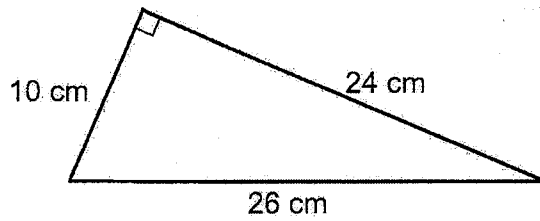

Do not write
in this space

- (a) Find the area of the triangle.
- (b) Dinesh wants to cut such triangles from a rectangular piece of cardboard 60 cm by 100 cm. At most, how many of such triangles can he cut?

Ans: (a) _____ [1]

(b) _____ [3]

- 14 The figure shows a path of width 2 m in a rectangular garden of length 28 m. The outline of the path is made up of quarter circles with centre W, semicircles with centre Z and straight lines. $WX = YZ$.

Do not write in this space

- (a) What is the width of the rectangular garden?
 (b) Find the area of the path. Take $\pi = 3.14$.

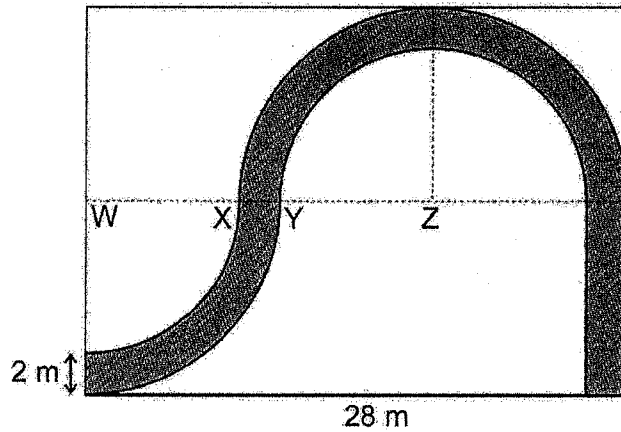

Ans: (a) _____ [1]

(b) _____ [3]

- 15 Yan filled two types of bottles, large and small, with the drink she made. She filled 3 large bottles and 5 small bottles with 7.2 ℓ of the drink.

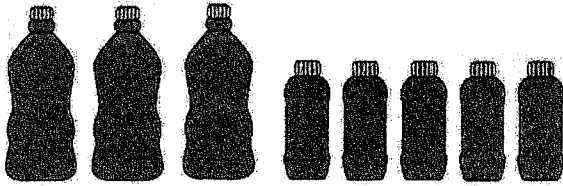

She could not fill another large bottle with the remaining drink as she was short of 0.5 ℓ. Instead, she filled another small bottle and had 0.3 ℓ of the drink left.

- (a) How many more litres of drink did each large bottle hold than each small bottle?
- (b) How many litres of drink did Yan make?



Do not write
in this space

Ans: (a) _____ [1]

(b) _____ [3]

16 Peiyi and Jamal bought potted plants at the prices shown below.

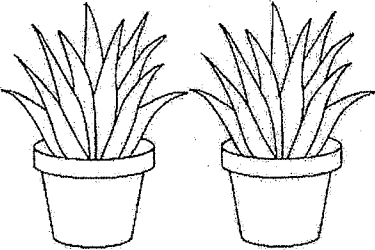
Do not write
in this space

Large potted plants	Small potted plants
	
2 for \$15	3 for \$10

- (a) Peiyi bought an equal number of large and small potted plants. She spent \$175 **more** on the large ones. How many potted plants did she buy altogether?
- (b) Jamal spent an equal amount of money on the large and small potted plants. What fraction of the potted plants he bought were large?

Ans: (a) _____ [3]

(b) _____ [2]

- 17 Three girls Amy, Beth and Cindy had the same number of coins. Amy and Beth each had a mix of fifty-cent and ten-cent coins. Amy had 9 ten-cent coins while Beth had 15 ten-cent coins. Cindy had only fifty-cent coins.

- (a) Of the three girls, who had the most money and who had the least?
- (b) What was the difference in the total value of Amy and Beth's coins?
- (c) Beth used all her fifty-cent coins to buy some food. She then had \$10 less in coins than Cindy. How many fifty-cent coins did Cindy have?

Do not write
in this space

Ans: (a) Most _____

Least _____ [1]

(b) _____ [2]

(c) _____ [2]

18 Ishak uses rods to form figures that follow a pattern. The first four figures are shown below.

Do not write in this space



Figure 1



Figure 2



Figure 3



Figure 4

(a) The table below shows the number of rods used for each figure. Complete the table for Figure 5 and Figure 6.

Figure Number	Number of rods used
1	10
2	15
3	18
4	23
5	
6	

[1]

(b) What is the difference in the number of rods Ishak would use for Figure 9 and Figure 11?

(c) How many rods would he use for Figure 30?

Ans: (b) _____ [1]

(c) _____ [2]

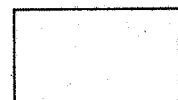

End of Paper

The information contained in this booklet is the property of the Government of the Republic of Singapore. Action will be taken against any person who makes unauthorised release or reproduction of this information, whether in whole or in part and in whatever format.

Those seeking permission to release or reproduce this information, in whole or in part and in whatever format, must direct their request in writing to the **Chief Executive, Singapore Examinations and Assessment Board**.

Any person who comes across this booklet must return it to the **Chief Executive, Singapore Examinations and Assessment Board** without delay.

Copyright Acknowledgements:

The Singapore Examinations and Assessment Board has made every effort to trace copyright holders, but if we have inadvertently overlooked any, we will be pleased to make the necessary arrangements at the first opportunity.